

2. In which of the following diagrams is one shape the reflection of the other in the mirror line shown? Make a correct diagram for those that are not correct.

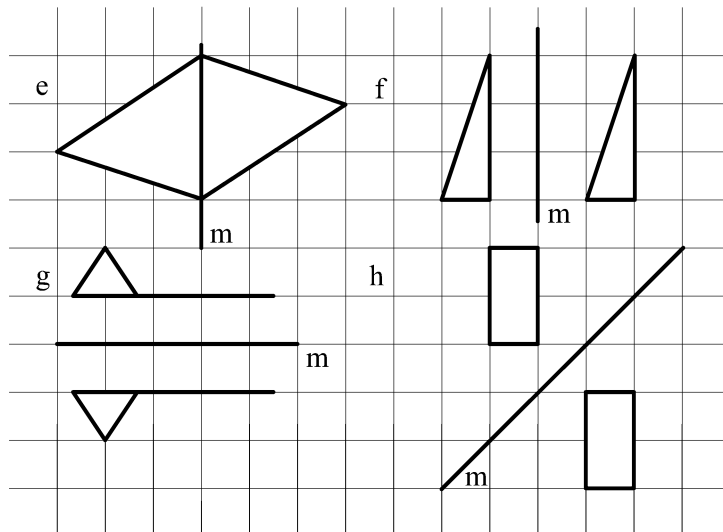

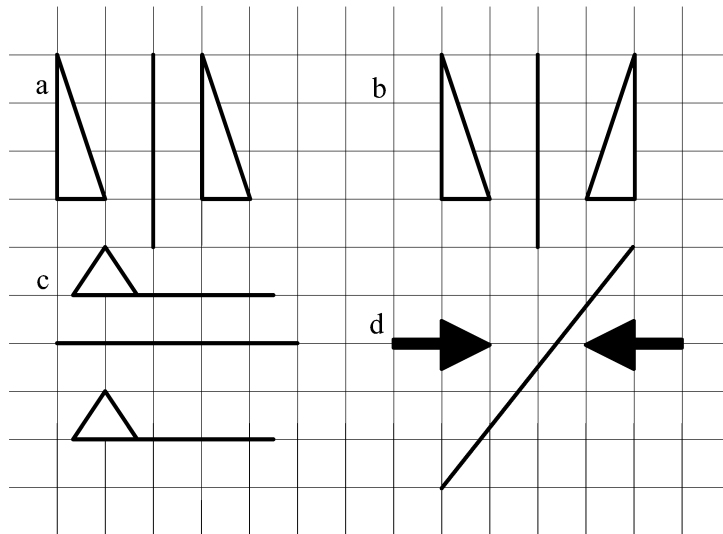

### Worksheet 4

1. Use a coordinate grid to find the coordinates of the image of the following points P when reflected in the  $y$ -axis.

Tabulate your results.

Coordinates original point	Coordinates of image
(3, 2)	
(-5, 2)	
(-2, 3)	
(7, -2)	
(-4, -5)	
(-1, 3)	
(4, 6)	
(5, -6)	
(-3, b)	
(a, 4)	
(a, b)	
(2a, 3b)	

2. Use a coordinate grid to find the coordinates of the image of the following points P when reflected in the  $x$ -axis.

Tabulate your results.

Coordinates original point	Coordinates of image
(3, 2)	
(-5, 2)	
(-2, 3)	
(7, -2)	
(-4, -5)	
(-1, 3)	
(4, 6)	
(5, -6)	
(a, -3)	
(4, b)	
(a, b)	
(2a, 3b)	

3. Use a coordinate grid to find the coordinates of the image of the following points P when reflected in the line with equation  $x = y$ .

Tabulate your results.

Coordinates original point	Coordinates of image
(3, 2)	
(-5, 2)	
(-2, 3)	
(7, -2)	
(-4, -5)	
(-1, 3)	
(4, 6)	
(5, -6)	
(-3, b)	
(a, 4)	
(a, b)	
(2a, 3b)	

4. Use a coordinate grid to find the coordinates of the image of the following points P when reflected in the line with equation  $y = -x$ .

Tabulate your results.

Coordinates original point	Coordinates of image
(3, 2)	
(-5, 2)	
(-2,3)	
(7, -2)	
(-4, -5)	
(-1, 3)	
(4, 6)	
(5, -6)	
(-3, b)	
(a, 4)	
(a, b)	
(2a, 3b)	

5. a) Look at your results in question 1 - 4. Summarise your findings by completing the following table.

Coordinates original point	Equation of line of reflection	Coordinates of image
(a, b)	$x = 0$	
(c, d)	$y = 0$	
(e, f)	$x = y$	
(g, h)	$x = -y$	

6. Complete the following table.

Coordinates original point	Equation of line of reflection	Coordinates of image
(3, -2)	$x = 0$	
(-5, -20)	$y = 0$	
(-2.3, 3.7)	$x = y$	
(9, -2)	$x = -y$	
	$x = 0$	(-5.6, 3.5)
	$y = 0$	(32, -45)
	$x = y$	(12, -8)
	$x = -y$	(-4.7, 7.3)
(5, -7)		(-7, 5)
(5, -7)		(-5, -7)
(5, -7)		(5, 7)
(5, -7)		(7, -5)



## Self mark exercise 2

1. Work the questions in worksheet 1.
2. Work the questions in worksheet 2.
3. Work the questions in worksheet 3.
4. Work the questions in worksheet 4.
5. Use squared paper.

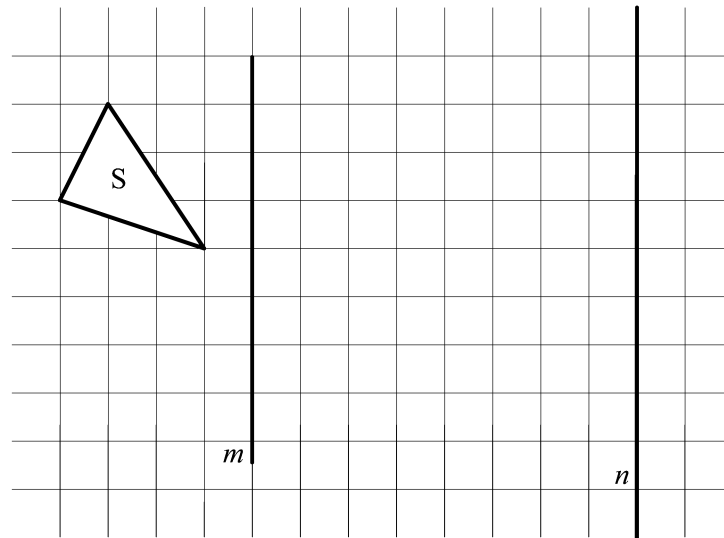

Reflect the shape  $S$  in the mirror line  $m$  to give  $S'$ , reflect  $S'$  in the mirror line  $n$  to give you  $S''$ . Investigate the relationship between  $S$  and  $S''$  for different distances between lines  $m$  and  $n$ .

6. Make a table for several points, as in worksheet 4, to find the coordinates of  $P(a, b)$  when reflected in
  - a) the line with equation  $x = 3$
  - b) the line with equation  $y = 3$
  - c) the line with equation  $x + y = 3$
  - d) the line with equation  $x - y = 3$
7. The point  $P(x, y)$  is reflected in the line with equation  $y = mx + n$ ; find the coordinates of  $P'$  the image of  $P$ .

*Check your answers at the end of this unit.*

## Section A7: Finding the equation of the line of reflection on a coordinate grid



If you are given a shape and its image under a reflection, you can find the line of reflection and its equation in most cases by careful inspection of the diagram.

The results you obtained in the previous exercises (the midpoint of the line segment joining point and its image is on the mirror line/line of reflection; the mirror line is perpendicular to the line joining a point and its image) allows also an algebraic approach.

### Example

The line segment PQ with coordinates of the end points P(1, 3) and Q(-2, 3) is reflected. The image is P'Q' where the coordinates of P' are (2, 1). Find the equation of the line of reflection.

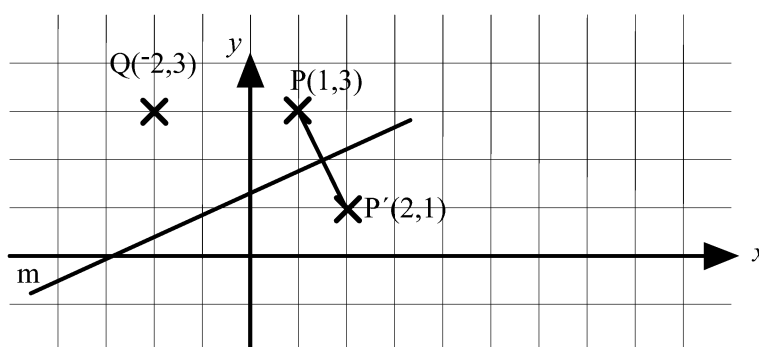

The coordinates of the midpoint of PP' are  $\left(\frac{1+2}{2}, \frac{3+1}{2}\right) = \left(1\frac{1}{2}, 2\right)$ .

The gradient of PP' is  $\frac{3-1}{1-2} = -2$ .

If the line perpendicular to PP' has a gradient  $p$  then  $-2 \times p = -1$  and  $p = \frac{1}{2}$ .

The line of reflection passes through the midpoint of PP' the point with coordinates  $\left(1\frac{1}{2}, 2\right)$  and is perpendicular to PP' with gradient  $\frac{1}{2}$ .

Hence the equation is of the format  $y = \frac{1}{2}x + c$ .

Substitution  $\left(1\frac{1}{2}, 2\right)$  gives:  $2 = \frac{1}{2} \times 1\frac{1}{2} + c$ . So  $c = 2 - \frac{3}{4} = 1\frac{1}{4}$ .

The equation of the line of reflection is therefore  $y = \frac{1}{2}x + 1\frac{1}{4}$ .

N.B. The coordinates of Q are NOT relevant at all. It is sufficient to have given the coordinates of one point and its image under the reflection.



### Self mark exercise 3

1. Describe fully the following reflections by giving the equation of the line of reflection.

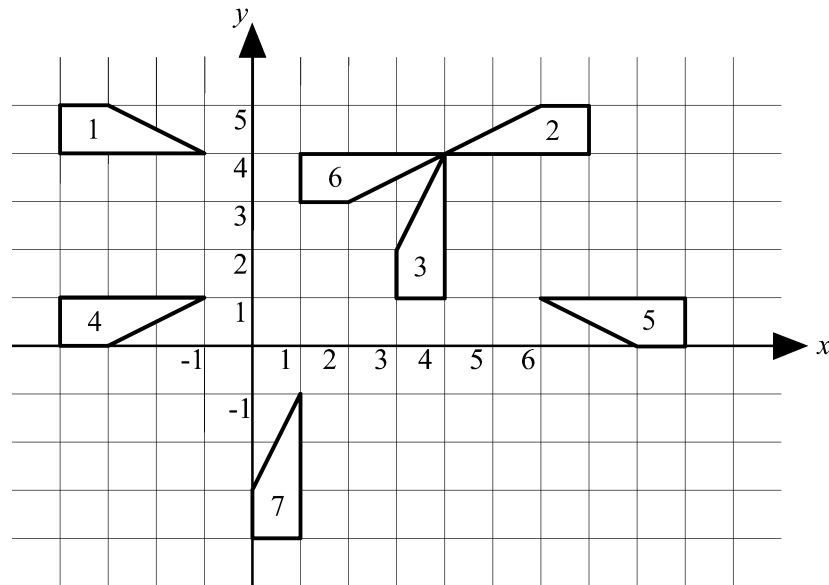

- a) 1 onto 2    b) 2 onto 3    c) 1 onto 4    d) 4 onto 5  
e) 3 onto 6    f) 4 onto 7
2. Given are the coordinates of the vertices of the triangles:  
 $\Delta 1$ : (-1, 2), (-1, 5), (-2, 5)     $\Delta 2$ : (5, 2), (5, 5), (6, 5)  
 $\Delta 3$ : (5, 0), (5, -3), (6, -3)     $\Delta 4$ : (0, 3), (-3, 3), (-3, 4)  
 $\Delta 5$ : (-1, 2), (2, 2), (2, 1)

For the following mappings (i) draw the triangles on a square grid  
(ii) draw the mirror line (iii) find the equation of the line of reflection  
(mirror line)

- a)  $\Delta 1$  onto  $\Delta 2$     b)  $\Delta 2$  onto  $\Delta 3$     c)  $\Delta 1$  onto  $\Delta 4$     d)  $\Delta 1$  onto  $\Delta 5$

*Check your answers at the end of this unit.*



### Unit 3, Practice activity 2

1. Choose one or more of the activities on reflection presented above in the worksheets and self-mark exercises. Adapt the activity to meet the situation in your classroom and try them out. Write an evaluative report paying specific attention to the common errors diagnosed earlier.
2. Water utilities is to make a bore hole along the riverbed PQ.

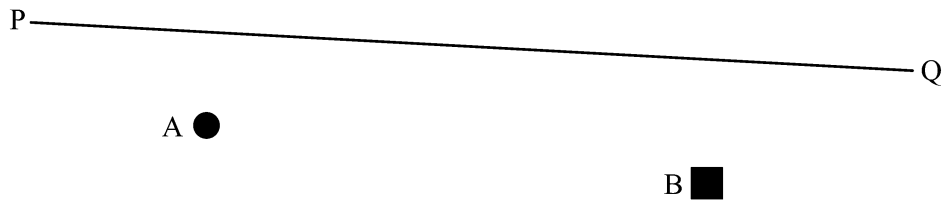

The houses A and B are to be connected. Where is the bore hole to be made to minimise the length of pipe needed to connect A and B to the bore hole?

*Present your assignment to your supervisor or study group for discussion.*



## Section B: Rotation



### Section B1: Points to keep in mind as a teacher when covering rotation

1. A practical hands-on approach is needed. Rotation of shapes is investigated by copying the shape on tracing paper and rotating the paper about the given centre through the given angle. An instruction sheet for pupils is provided on a following page.
2. Clockwise rotations are taken as negative and anticlockwise rotation as positive.
3. Use initially **plain paper** for rotations as this has been found easier before moving to shapes on a grid. The angle of rotation should be restricted to quarter, three quarter and half turns (both clockwise and anticlockwise).
4. Rotations are fully described by (i) centre of rotation (ii) direction of rotation (iii) measure of the angle of rotation.
5. The difficulty of questions on rotation depends on
  - (i) **Position of the centre of rotation.**

If the centre of rotation is outside the shape to be rotated the question becomes easier than when the centre of rotation is a point on the shape or inside the shape.
  - (ii) **The complexity of the given shape.**

Points are fairly easy to rotate, shapes of various form are harder. The implication is to emphasize to rotate a shape given on a grid 'point-wise,' i.e., by taking 'one corner' point at a time in case the tracing paper method is not used.
  - (iii) **Position of the object to be rotated.**

If the original shape is placed such that sides follow grid lines (horizontal and/or vertical) it results in an easier question than when the object is placed sloping with respect to the grid lines.

The following diagram illustrates questions on rotation in increasing level of difficulty. In all cases the shape is to be rotated through a quarter turn anticlockwise about the centre O.

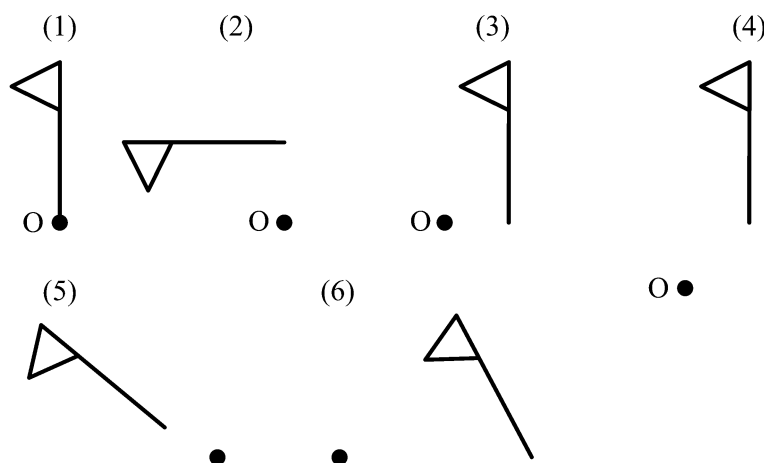

6. Three types of questions have to be covered
- given the centre, the measure of the angle of rotation and the shape, to find the image of the shape when rotated about the centre.
  - given the centre, the shape and an 'image', to find the measure of the angle of rotation.
  - given a shape and an image of the shape, to find the centre of rotation (if any) and the measure of the angle of rotation.

The above in combination with (i) the centre of rotation outside, on or inside the shape (ii) a variety of positions of the shape (iii) using grid/coordinates or plain paper.

7. A good amount of practice of rotating of shapes is need.
8. The main properties of a rotation are used for finding the centre of rotation and the angle of rotation other than by inspection (which is the common method for pupils at lower secondary school).

In a rotation about O in which A maps onto A'

- the angle of rotation is the angle AOA'.
- the perpendicular bisector of AA' passes through the centre O.



### Unit 3, Practice activity 3

- Design a diagnostic test to find out pupils' common errors when rotating shapes. Ensure all possible cases are covered: rotation with or without grid, centre of rotation outside, on or inside the shape, variety of positions of the object with respect to the centre of rotation. For each item state the objective: What error is the item to diagnose?
- Administer the test and analyse the results.

*Present your assignment to your supervisor or study group for discussion.*

## Section B2: How to draw rotations



The following is an outline of an instruction sheet for pupils.

### Instruction sheet.

If you want to rotate a given shape  $S$  about a given centre  $O$  follow the following steps.

*Step 1.* At the centre of rotation  $O$  fix a 'twelve o'clock' direction.

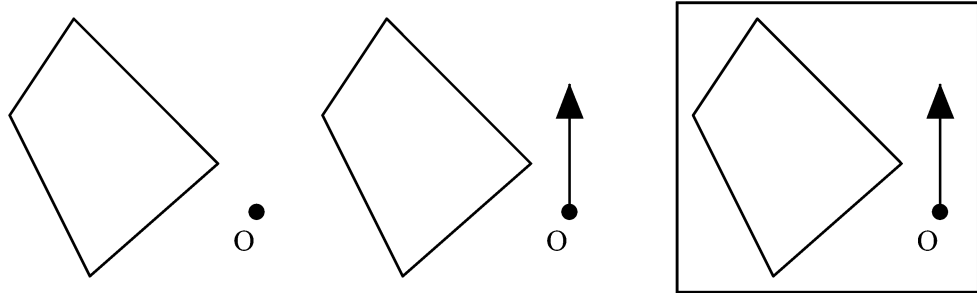

*Step 2:* Place tracing paper on top of the shape and copy the shape, the centre  $O$  and the 'twelve o'clock' direction. This tracing is your template.

*Step 3.* Put after tracing the point of your compasses through the template at  $O$  (do not move the template as yet).

*Step 4.* Rotate the template through the required angle. You set the 'clock' at the correct time. In the diagram the shape is rotated through  $-90^\circ$  ( $90^\circ$  clockwise, so the two 'hands', on the original paper and on the template are at 'three o'clock').

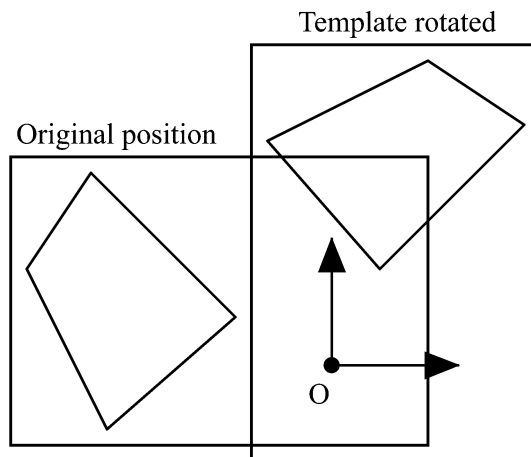

*Step 5.* Mark through the template, with another compass or sharp pencil, the position of the vertices of the shape in its new position.

Remove the template and connect the marked points to obtain the shape in its rotated position (the image of the original shape).

In the diagram, the vertices and their images have been labeled. As a check  $OB$  and  $OB'$  have been drawn. It is easily checked with a set square that the angle  $BOB'$  is indeed  $90^\circ$ .

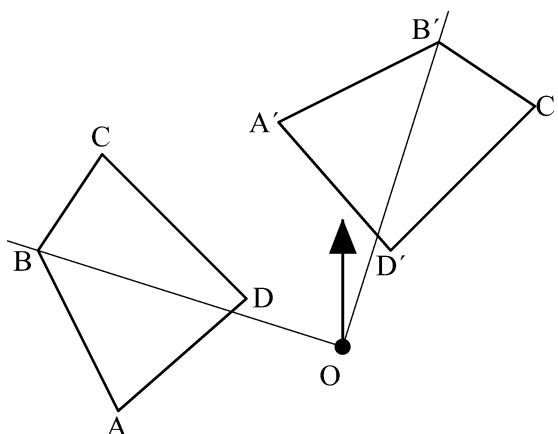

### Section B3: Examples of type of questions on rotation for the classroom



This section gives examples of the different type of questions to be covered in a classroom situation. Each type of question would need to be extended with similar examples to give sufficient practice and consolidation to the pupils and to cover all possible cases.

The examples cover the following objectives:

*Question 1 and 2:* Given a shape, the centre of rotation and the angle of rotation pupils are expected to draw the image (using tracing paper).

*Question 3:* Pupils are to discover the relationship between the coordinates of the original point  $P(a, b)$  and its image after rotating about  $O(0, 0)$  through (i)  $90^\circ$  (ii)  $180^\circ$  (ii)  $-90^\circ (= 270^\circ)$ .

*Question 4:* Pupils are to find centre and angle of rotation given a shape and its image after a rotation.



### Self mark exercise 4

1. Work the questions below.

*Check your answers at the end of this unit.*

1. Copy the shapes below on squared paper, then use tracing paper to rotate the shape about the centre through the angle indicated.

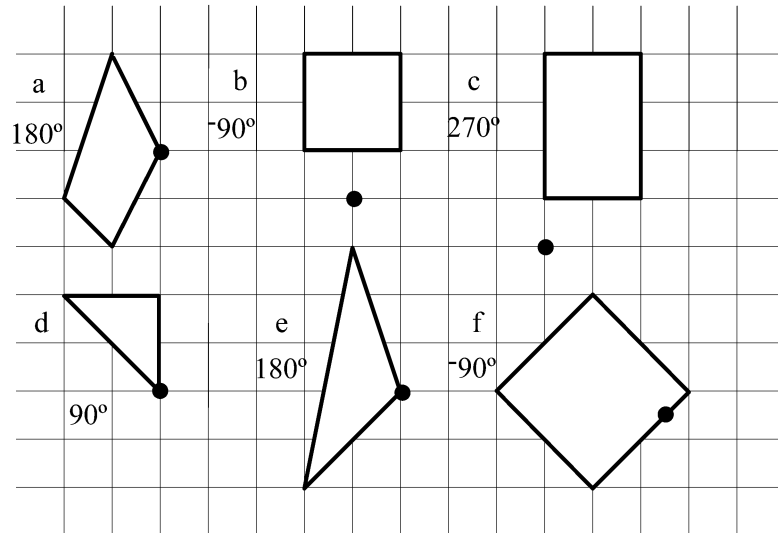

2. Copy each rectangle and using A4 paper and tracing paper rotate each of the rectangles about O through the angle indicated.

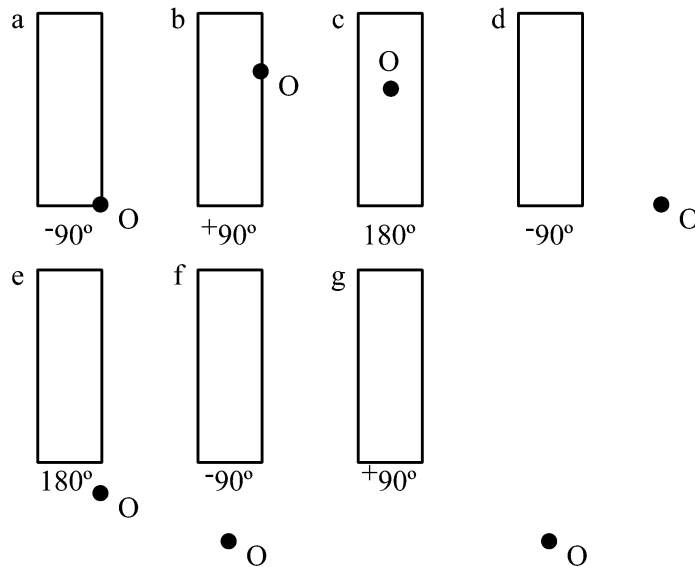

3. a) Plot the points A(3, 2) B(2, -3) C(-4, -5) and D(-6, 2)

Rotate each point about O(0, 0) through  $90^\circ$  clockwise. Tabulate the points and their images.

POINT	IMAGE
A(2, 3)	A'( , )

Can you find a relationship between the coordinates of the point and its image?

Check your conjecture for a few more points.

What would be the image of P(a, b) under a rotation of  $90^\circ$  clockwise ( $-90^\circ$  rotation)?

b) Repeat above for a rotation about O through  $180^\circ$

c) Repeat above for a rotation through  $-90^\circ$  (which is the same as  $-270^\circ$ )

4. Copy the shapes using tracing paper or make cutouts of the shapes. Use your aid to help you to mark the centre of rotation for each pair of congruent shapes. Write down the angle of rotation in each case.

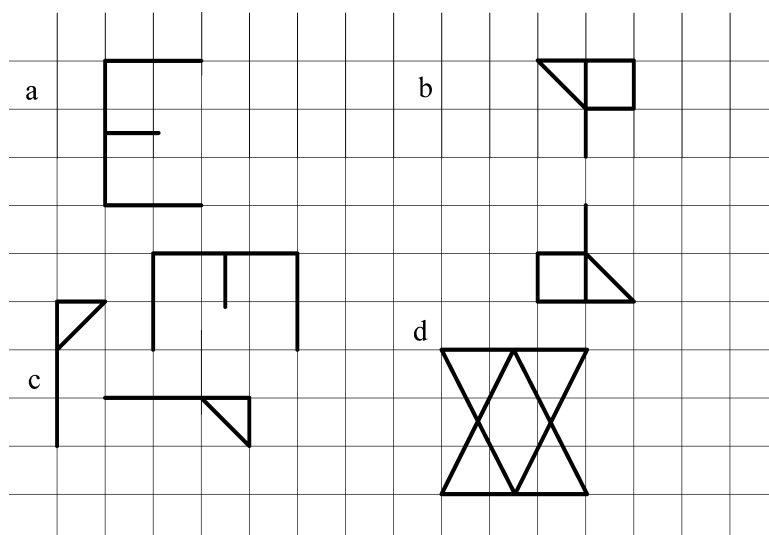

### Unit 3, Practice activity 4

- Choose one of the sample type of questions on rotation you covered above and develop/extend the objective of the question into a complete class activity. Ensure you cover all possible cases with (i) the centre of rotation outside, on or inside the shape (ii) a variety of positions of the shape (iii) using grid/coordinates or plain paper.

Try it out in your class and write an evaluative report.

- Write an outline for a coursework assignment on rotation and indicate expected outcomes.

*Present your assignment to your supervisor or study group for discussion.*

## Section C: Translation



This section covers translation of shapes.

### Section C1: Points to to keep in mind as a teacher when covering translation

- Translations or shifts are best described with column vector as illustrated in the diagram

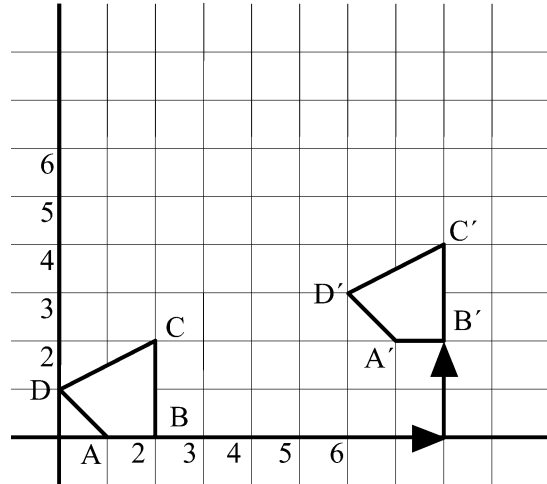

Shape ABCD (the original) has shifted to A'B'C'D' (the image). A'B'C'D' is a **translation**—a straight movement without turning—of ABCD.

The point A moved 6 squares to the right and 2 squares up to A'. So did the point B move to B', C to C' and D to D' (check it!).

- A short notation is used to describe this translation:

$$\overrightarrow{AA'} = \overrightarrow{BB'} = \overrightarrow{CC'} = \overrightarrow{DD'} = \begin{pmatrix} 6 \\ 2 \end{pmatrix}$$

It is called a vector, as it has both a length and a direction.

Single letters with an arrow above can also be used to indicate vectors.

For example,  $\overrightarrow{A'A}$

- To move from A' to A you move six squares to the left and two squares down. It is the opposite of moving from A to A'. The notation used is

$$\overrightarrow{a} = \overrightarrow{A'A} = \begin{pmatrix} -6 \\ -2 \end{pmatrix}$$

- The topic does not give as many problems as reflection and rotation. The main point to pay attention to is, as with coordinates, the order in which the numbers are written in the column vector. In  $\begin{pmatrix} a \\ b \end{pmatrix}$  the number  $a$  represents the horizontal and the number  $b$  the vertical shift.
- Type of questions to cover the topic:
  - given a shape and the translation vector, draw the image (or find the coordinates of the vertices of the image).
  - given a shape and its image under a translation, find the translation vector.



## Section C2: Examples of type of questions on the topic for the classroom

This section gives examples of the type of questions to be covered with the pupils. The objectives of the questions are that the pupil should be able to

*Question 1:* Translate a given shape by a given translation vector.

*Question 2:* Translate a given shape by a given translation vector in order to discover the relationship between the coordinates of the original shape, the translation vector and the coordinates of the image.

*Question 3:* Describe a translation using a column vector given a shape and its image without coordinates.

*Question 4:* Describe a translation using a column vector given a shape and its image on a coordinate grid.

*Question 5:* Describe a translation using a column vector given the coordinates of the original and its image.



### Self mark exercise 5

1. Work the questions below.

*Check your answers at the end of this unit.*

1. Copy on squared paper and translate triangle A by each of the following translation vectors

a)  $\begin{pmatrix} 3 \\ 0 \end{pmatrix}$  b)  $\begin{pmatrix} 0 \\ 4 \end{pmatrix}$  c)  $\begin{pmatrix} 2 \\ 3 \end{pmatrix}$  d)  $\begin{pmatrix} 5 \\ 2 \end{pmatrix}$

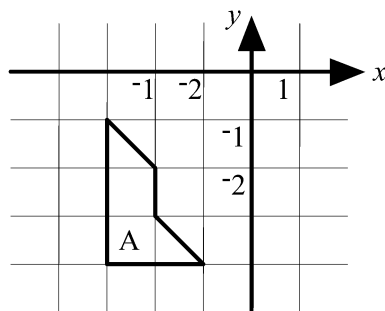



2. Copy the quadrilateral ABCD on squared paper and translate it by

- a)  $\begin{pmatrix} 0 \\ 3 \end{pmatrix}$    b)  $\begin{pmatrix} -3 \\ 0 \end{pmatrix}$    c)  $\begin{pmatrix} 2 \\ 5 \end{pmatrix}$    d)  $\begin{pmatrix} -2 \\ -4 \end{pmatrix}$    e)  $\begin{pmatrix} 5 \\ -6 \end{pmatrix}$

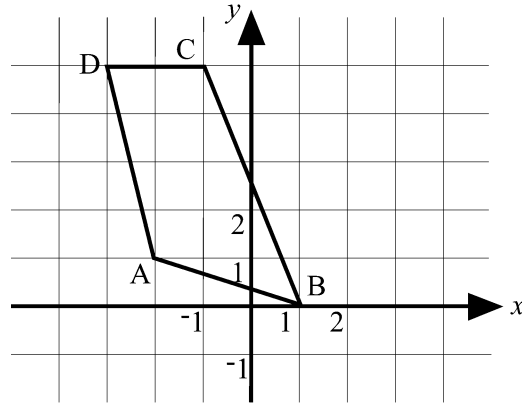

f) Tabulate the coordinates of A, B, C and D and the images.

	a	b	c	d	e
A(-2, 1)					
B					
C					
D					

g) What is the relationship between the coordinates of the original  $P(x, y)$ , the translation vector  $v = \begin{pmatrix} p \\ q \end{pmatrix}$  and the coordinates of the image  $P'$ ?

3. Use vectors to describe the translation of the white shape (the original) to the position of the black shape (the image).

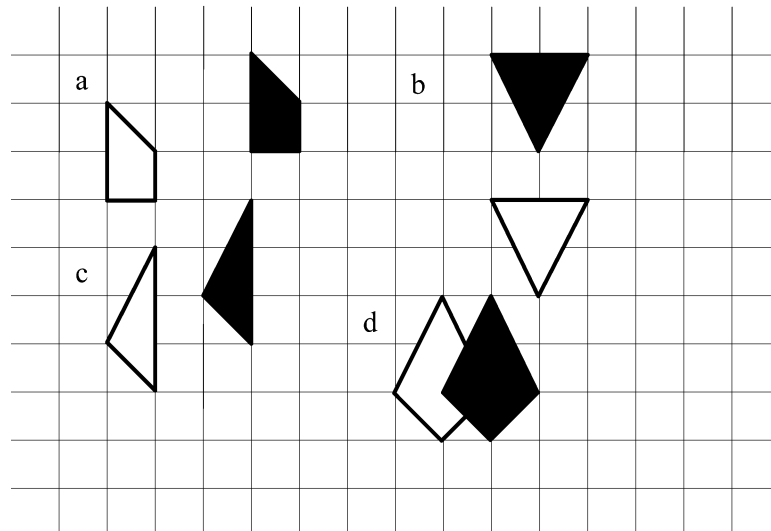

4. Describe fully each of the following translations:
- a) shape 1 onto shape 2      b) shape 1 onto shape 3  
 c) shape 1 onto shape 4      d) shape 1 onto shape 5  
 e) shape 2 onto shape 3      f) shape 2 onto shape 4  
 g) shape 5 onto shape 4      h) shape 5 onto shape 2

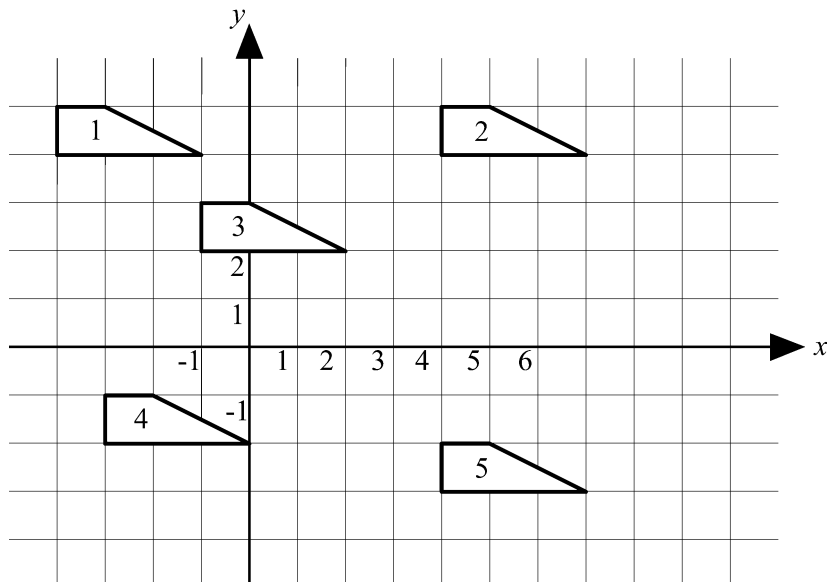

5. Find the translation vector given a point and its image.
- a)  $P(2, 3) \Rightarrow P'(5, 7)$   
 b)  $Q(-5, -2) \Rightarrow Q'(1, 0)$   
 c)  $R(0, 3) \Rightarrow R'(0, -5)$   
 d)  $S(-4, -6) \Rightarrow R'(-2, -7)$   
 e)  $T(1, -8) \Rightarrow T'(-4, -4)$



### Section C3: Game to consolidate the use of translation vectors

#### Impala hunt

Needed:

- number cards  $-6, \dots, -1, 1, 2, 3, \dots, 6$
- (2 $\times$ ) game board and counters in different colours for each player
- Cards for “Impala hunt”—for one group copy twice

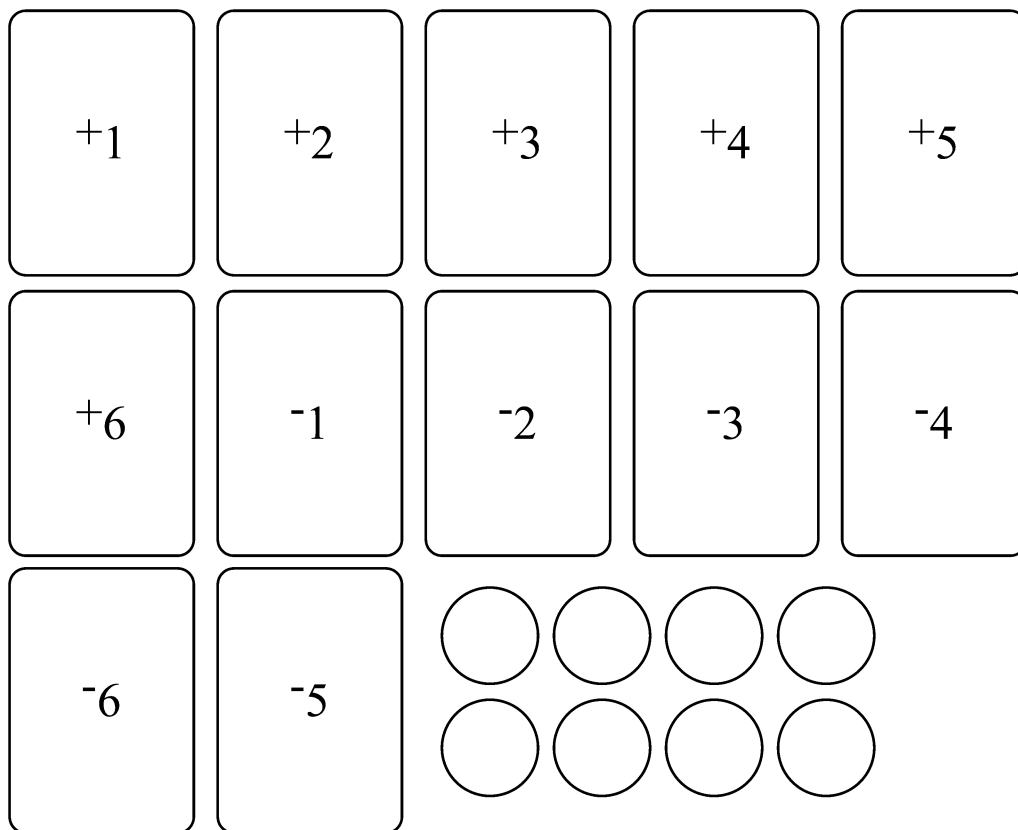

**Rules:**

Shuffle cards and place them face down.

Players take turns in taking two cards and using them to make a vector, e.g., if the two cards are -2 and +4 the vector  $\begin{pmatrix} -2 \\ +4 \end{pmatrix}$  or  $\begin{pmatrix} +4 \\ -2 \end{pmatrix}$  can be made.

From start move a counter according to the vector made.

Aim: to capture as many impalas as possible (counter remains on the impala).

Winner: player having captured most impalas.

### Game Board for “Impala Hunt”

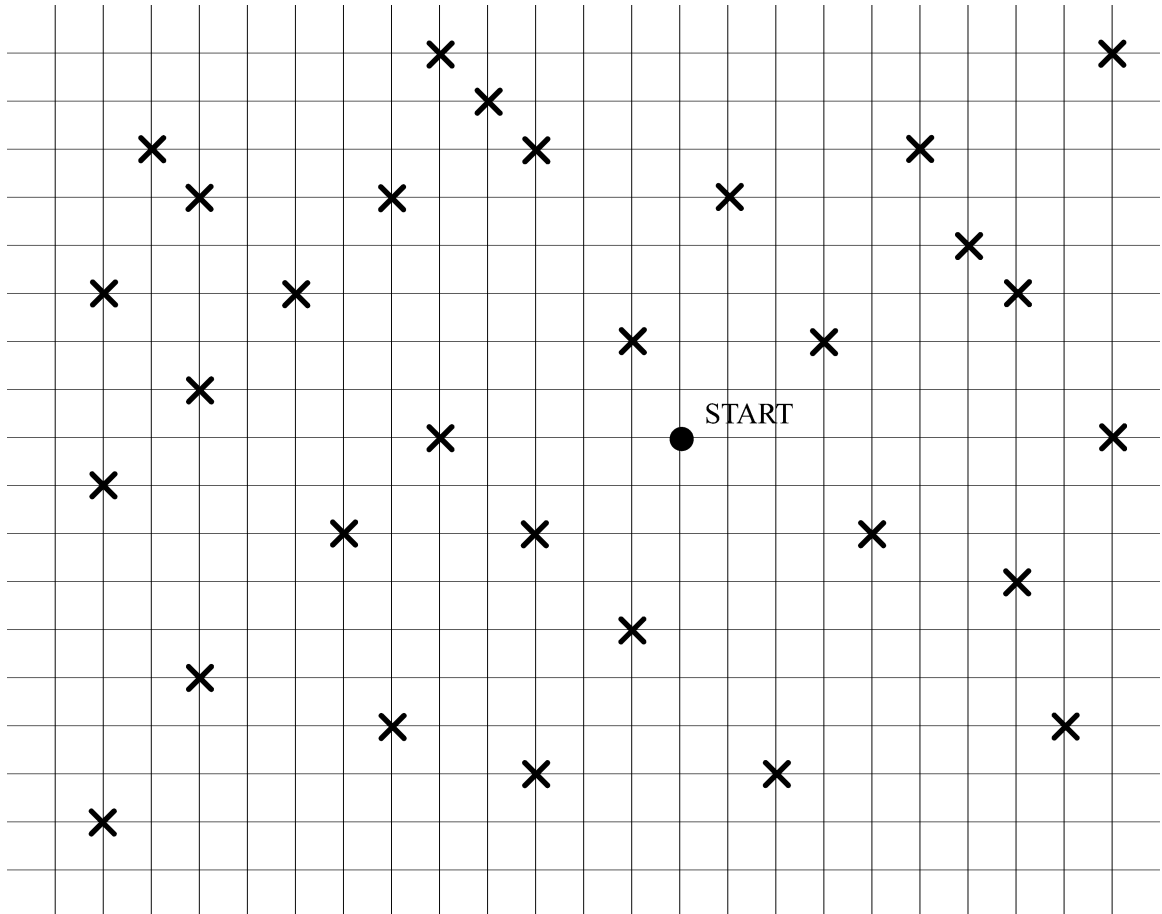

#### Unit 3, Practice activity 5

1. Make a sufficient number of ‘impala’ hunt games for your class. Have pupils play ‘impala hunt’.  
Try it out in your class and write an evaluative report.
2. Design and describe in detail a game to consolidate reflection, rotation and translation of shapes. Try it out with your class and write an evaluative report.

*Present your assignment to your supervisor or study group for discussion.*

## Section D: Enlargement

This section considers a transformation in which the size of the shape changes: enlargements. The word suggests that the image of the shape will be larger in size than the original shape. However this need not be the case. In mathematics the word enlargement is also used if the image is smaller in size than the original.

### Section D1: Similar and congruent shapes

In translations, reflections and rotation the image and the original shape have the same shape and size. If cut out they fit into each others opening. The shapes are **congruent**.

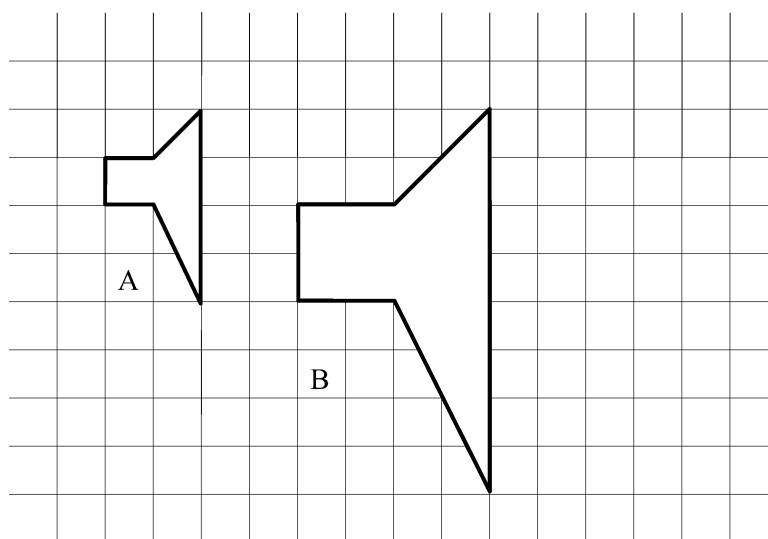

Shape A and B have the same shape but are different in size. The length measurements in shape B are twice those in shape A. B is a **scale diagram** from A by a **scale factor** 2. The shapes A and B are similar. You could say that for congruent shapes the scale factor is 1.

This diagram illustrates the enlargement of triangle ABC from centre O by scale factor 3.  $OA' = 3OA$ ,  $OB' = 3OB$  and  $OC' = 3OC$

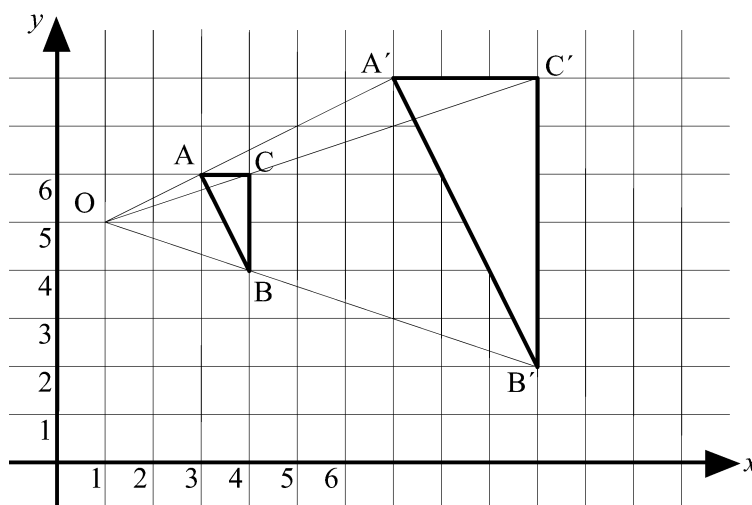

The mathematical meaning of similar is concise: in similar shapes corresponding lengths have the same ratio (the scale factor) and

corresponding angles are equal in size. In day to day use “similar” is used in a less strict way: “about the same looking”.

A **sorting** activity is needed to get the concept of similar clear in the minds of the pupils. On this activity pupils should work in groups to discuss whether or not shapes are similar. Real objects and photographs of objects should be used apart from ‘abstract’ diagrams like the ones below for a discussion exercise for the pupils.

### Discussion exercise 1

Work through this exercise as a group. First each member of the group **thinks**. Next, **share** your thoughts. Discuss until you agree as group. Listen carefully to each others’ arguments.

1. Identify in the diagram the shapes that are congruent and the shapes that are similar.

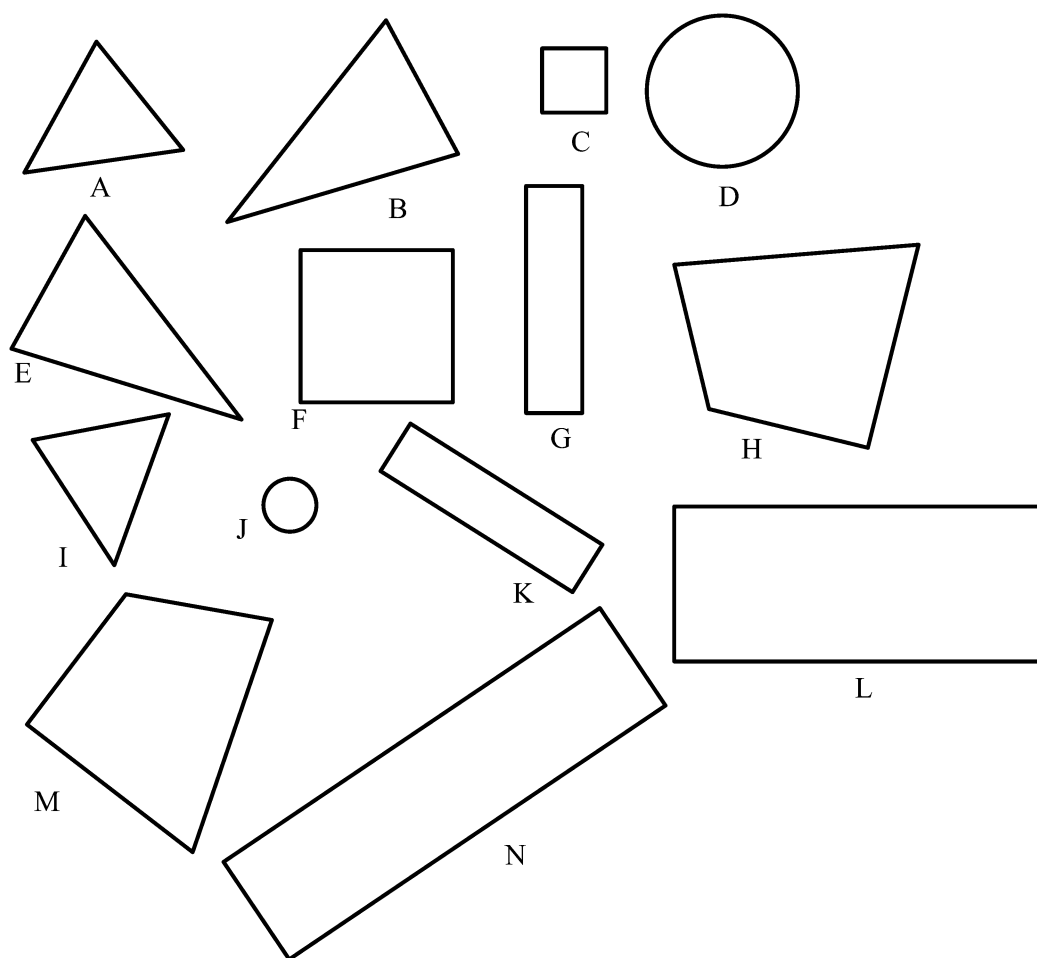

2. Which of the shapes B or C is NOT similar to A? Justify your answer.

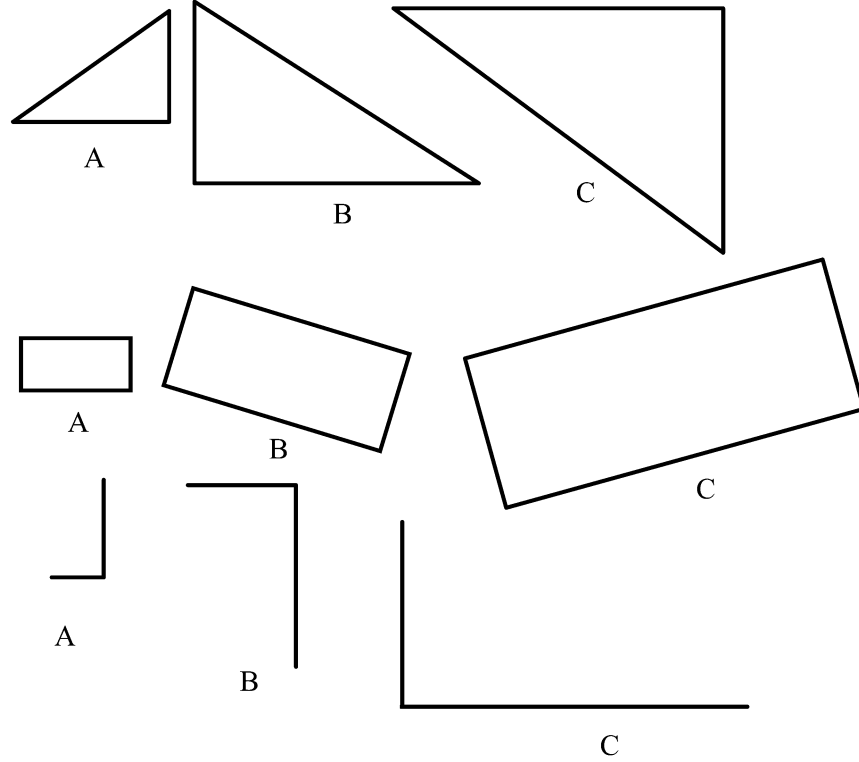

3. Discuss whether the following statements are true or false. Justify your answers using diagrams to give examples or non-examples to support your argument.

- Rectangles are always similar to each other.
- All squares are similar.
- All equilateral triangles are congruent, as their angles have equal sizes of  $60^\circ$ .
- Regular polygons are similar.
- Regular  $n$  sided polygons are similar.



### Self mark exercise 6

1. Answer the questions in discussion exercise 1 above.

*Check your answers at the end of this unit.*



## Section D2: Learning about enlargements

As is a transformation, an enlargement is determined by (i) the centre of enlargement (ii) the scale factor of the enlargement. The concept of enlargement is, as most concepts in mathematics, developed gradually. A scale diagram  $S'$  of a shape  $S$  need not to be a (direct) enlargement in the mathematical sense as there might not be a centre.

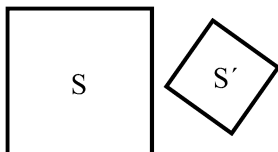

The two squares  $S$  and  $S'$  are similar, but  $S'$  cannot be obtained by enlarging  $S$  as there is no centre of enlargement. ( $S'$  can be obtained from  $S$  by more than one linear transformation applied in succession e.g. enlargement followed by rotation followed by translation.) The confusion is that a scale drawing of an object is often called an enlargement although there might not be a centre. As for linear transformations, enlargements require a centre of enlargement. It is advisable to use the word enlargement only if  $S'$  can be obtained from  $S$  by enlarging from a centre  $C$ . If there is no centre,  $S'$  is not an enlargement but a shape similar to  $S$  with a certain scale factor.

Two polygons are similar when they are equiangular and corresponding sides are in the same ratio. Equiangular polygons are not necessarily similar (e.g. a 3 cm by 3 cm square and a 6 cm by 8 cm rectangle are equiangular but corresponding sides do not have the same ratio and hence the two quadrilaterals are not similar). In the case of a triangle, however, if two triangles are equiangular then they are similar (and corresponding sides are in the same ratio). Also: If two triangles have corresponding sides in the same ratio then the two triangles are similar (and are equiangular).



Write down the different stages in the development of the concept 'enlargement' often covered in different year groups. What aspect of enlargement do you cover in which year?



Compare your list with the following sequence. Your order might differ at some points but the different aspects should be presented to pupils in a variety of activities.

- (i) identifying similar and congruent shapes (see discussion exercise 1).
- (ii) making a shape similar to a given shape by a whole number scale factor greater than 1 without reference to a centre. (The similar shape drawn might or might not be an enlargement depending on whether or not a centre can be found.)



*Example*

Copy each of the following shapes on squared paper and enlarge by the scale factor indicated.

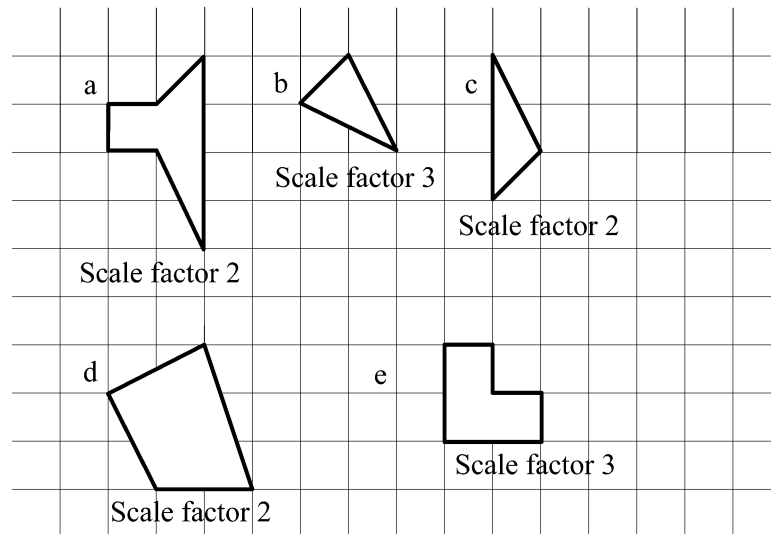

(iii) finding a scale factor by measuring corresponding lengths, the scale factor being a whole number greater than 1

To find the scale factor you find the ratio of the length of any two corresponding line segments in image and original

$$k = \frac{\text{length of image segment}}{\text{length of original segment}}$$

If the object and image are at opposite sides of the centre of enlargement you must place a negative sign with the above ratio.

*Example*

Shape B is similar to shape A. By taking appropriate measurements, find the scale factor.

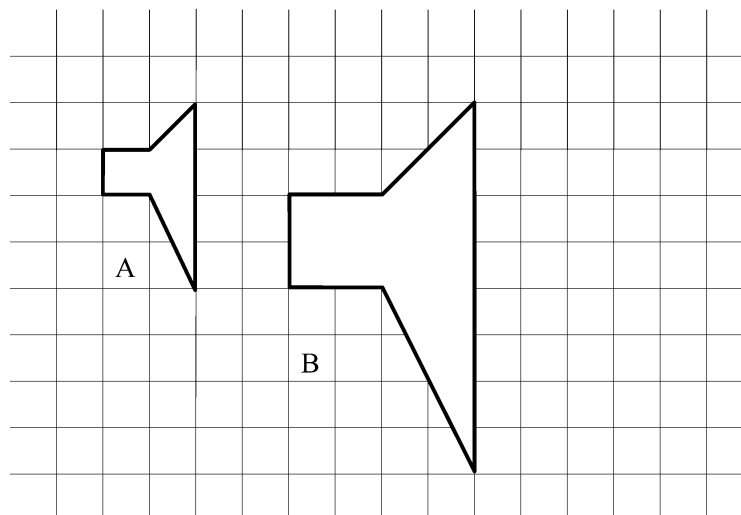

(iv) enlarging from a centre O with whole number scale factors greater than 1 with and without the presence of a grid, with the centre outside, on a side, at a vertex and inside the shape

*Examples*

Copy the following shapes on plain paper and enlarge each from the marked “A” or “B” centre by the scale factor that you indicate.

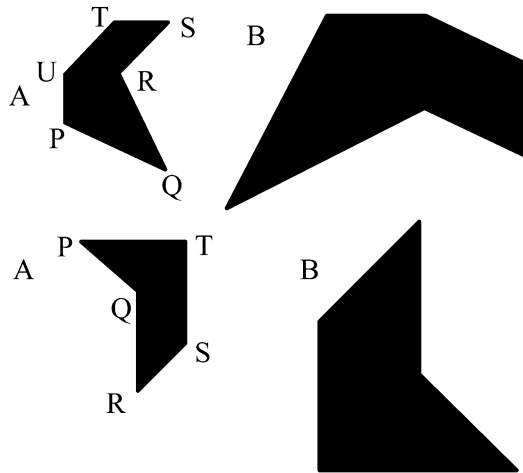

Copy each of the following shapes on square cm paper and enlarge the shape from O with the scale factor indicated. Label the vertices of the object A, B, C, ... and its image A', B', C', ...

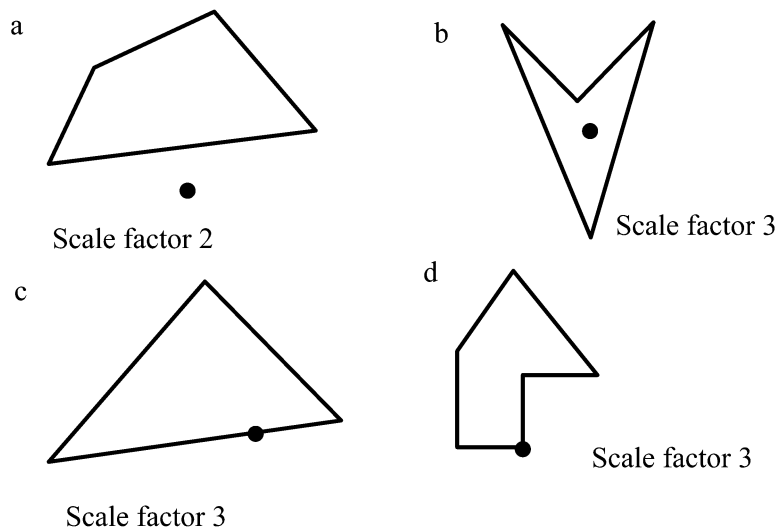

(v) discovering the relationships

- a) In an enlargement, the ratio (lengths of image of line segment):  
(lengths of line segment) is constant and equal to the scale factor.
- b) In an enlargement, a line segment and its image are parallel.
- c) In an enlargement, the line joining a point with its image passes through the centre of enlargement.

*Example*

- On paper, draw a diagram similar to the one below. Join the point O (the centre of enlargement) with A, B and C.
- Measure OA. Using the scale factor 3, mark A' such that OA' is  $3 \times OA$ .

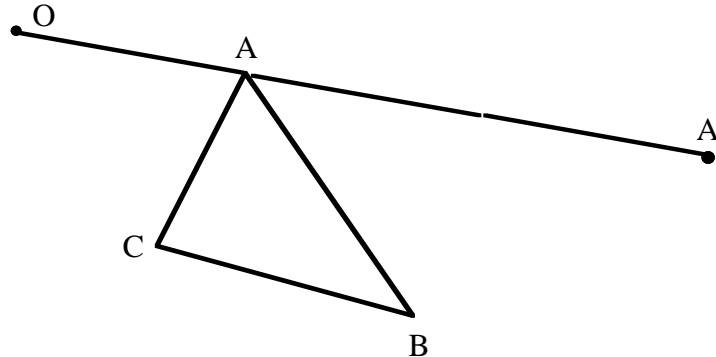

- Repeat for the point B to find a point B' and for C to find a point C'. Join A'B'C' to form triangle A'B'C' an enlargement of triangle ABC by scale factor 3. Check that the lengths of the sides of triangle A'B'C' are three times the length of the corresponding sides of triangle ABC.
  - Compare the directions of AB and A'B', of BC and B'C' and of AC and A'C'. What do you notice?
  - Start with another shape, for example a quadrilateral PQRS, and enlarge it from a centre O by a scale factor 2. Check your observation of (d).
- (vi) application of the property (c) listed in (v) above: finding the centre of enlargement. The shapes might be given on a grid or not. The centre can be positioned outside, on a side, at a vertex or inside the shape.

To find the centre of enlargement connect points with their image. For example P with P' and Q with Q'. The point of intersection of PP' and QQ' is the centre C(-1, 4) of enlargement as illustrated in the diagram.

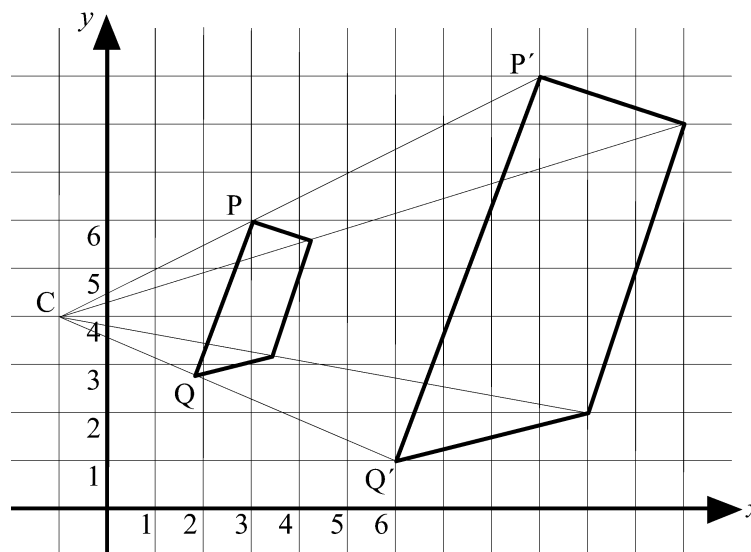

*Examples*

Find the centre of enlargement in each of the following figures.

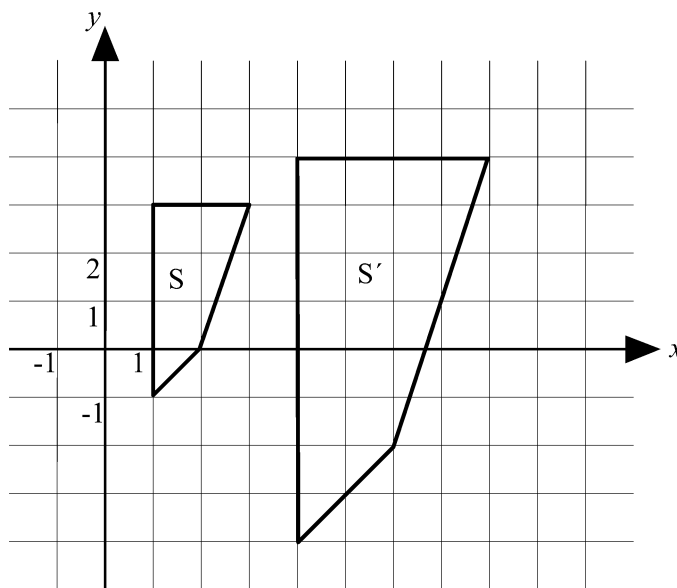
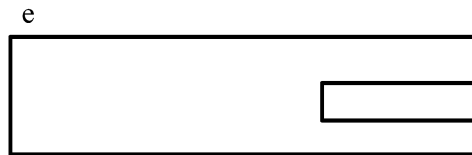
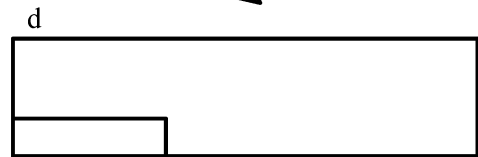
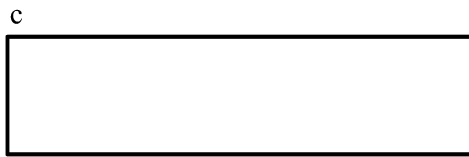
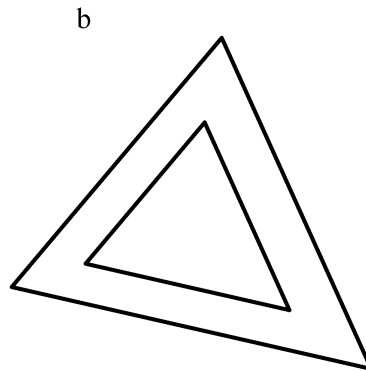
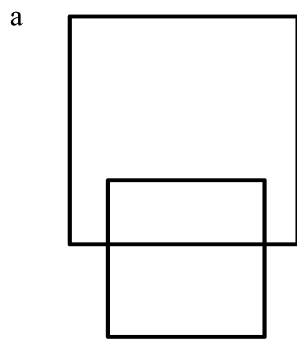

(vii) enlarging by fractional ( $-1 < k < 1$ ,  $k \neq 0$ ) and negative scale factors from a centre O. Enlargement by fractional scale factor ( $-1 < k < 1$ ,  $k \neq 0$ ) gives an image that is smaller in size, yet it is called enlargement. With negative scale factors the image and objects are at opposite sides of the centre of enlargement.

*Example*

Enlarge triangle ABC from centre O by scale factor  $\frac{1}{2}$ . Connect O with A and find A' on OA such that  $OA' = \frac{1}{2} OA$ . Repeat for the other points.

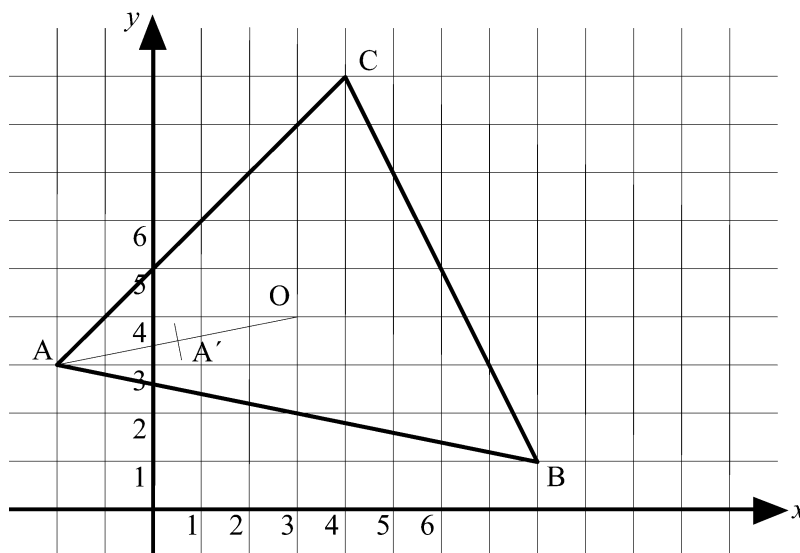

Enlarge triangle ABC from centre O with scale factor -2. Connect O with A, produce AO to A' such that  $OA' = 2 OA$ . Repeat for the other points.

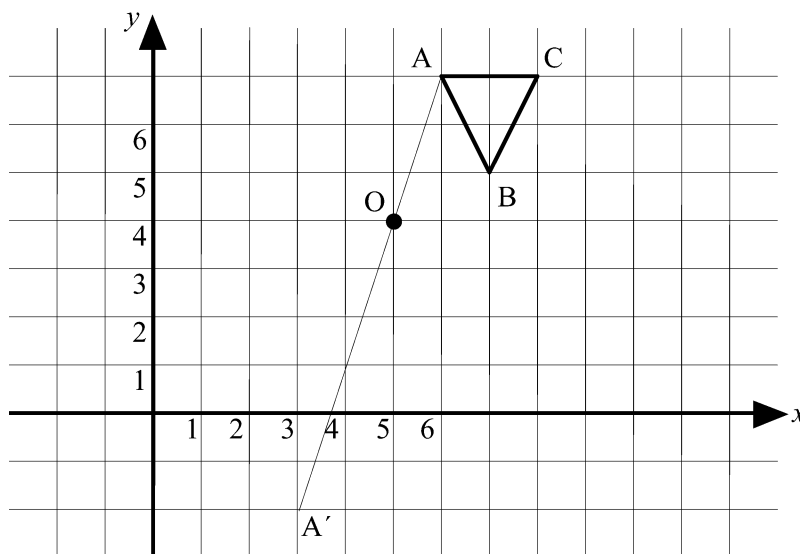

(viii) enlarging on a grid from  $O(0, 0)$  and discovering that the coordinates of the original  $P(x, y)$  map onto  $P'(kx, ky)$  under an enlargement centre O, scale factor k.

*Example*

- a) On a square grid draw a coordinate system and plot the points A(2, 1), B(1, 3) C(-1, -1) and D(1, -2). Complete the quadrilateral ABCD.

Enlarge ABCD with centre O(0, 0) by scale factor 2, 3 and 4 respectively.

Write down the coordinates of the image points in the table below.

Original	A(2, 1)	B(1, 3)	C(-1, -1)	D(1, -2)
Scale factor 2				
Scale factor 3				
Scale factor 1.5				
Scale factor 10				
Scale factor 50				
Scale factor $n$				

- b) Look at the pattern. Can you easily find the coordinates of the image points if you know the scale factor?

Complete the last three rows in the table.



**Self mark exercise 7**

1. Work the example questions in the preceding outline.
2. Look at the following statements and decide whether they are always true, sometimes true or always false. Justify your answer illustrating with examples.
  - a) If  $S'$  is an enlargement of  $S$  then  $S'$  and  $S$  are similar.
  - b) If  $S'$  and  $S$  are similar then  $S'$  is an enlargement of  $S$ .
  - c) All squares are enlargements of each other.
  - d) All squares are similar.
3. Enlarge a shape  $S$  by a scale factor  $p$  to give  $S'$ . Enlarge  $S'$  using a scale factor  $q$  to give you  $S''$ . Investigate the relationship between  $S$  and  $S''$ .

*Check your answers at the end of this unit.*



Transformation geometry calls for a practical method: pupils moving, flipping, rotating shapes. Enlargement concepts can be developed using an elastograph to enlarge shapes.

The elastograph is a simple device for enlarging (which includes reducing in size: scale factor  $s$  of enlargement is in the range  $1 < s < \infty$ ,  $s \neq 0$ ) diagrams. It can be used as a practical method for the introduction of scale factors (i.e. ratios of enlargement).

The length of elastic used should be capable of stretching to at least three times its natural length in order to produce reasonable sized drawings.

Below you find an outline for a worksheet for the pupils for use in the classroom as a first introduction to enlargement.



### Worksheet.

Work in pairs.

1. To make an elastograph you take a piece of elastic and make 3 marks on it 3 cm apart with a ball point pen. Call the points P, Q and R.

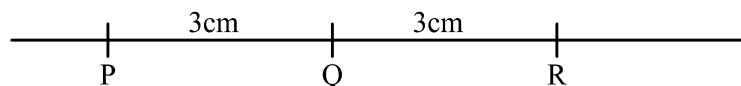

2. One person holds P fixed and moves R around the diagram of the face. The other person marks the path of Q.

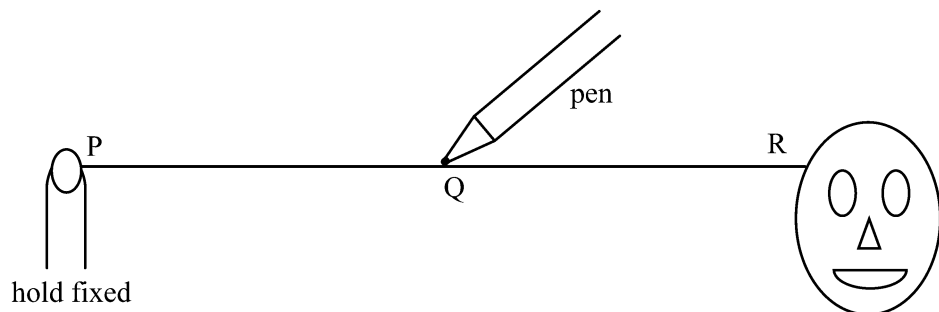

3. Do the same for the following shapes:

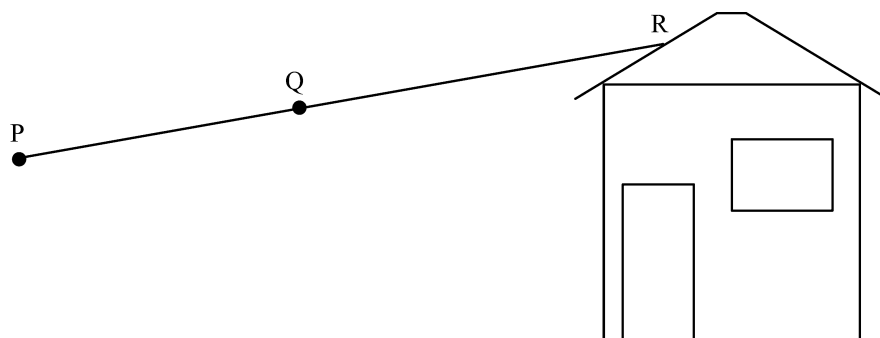

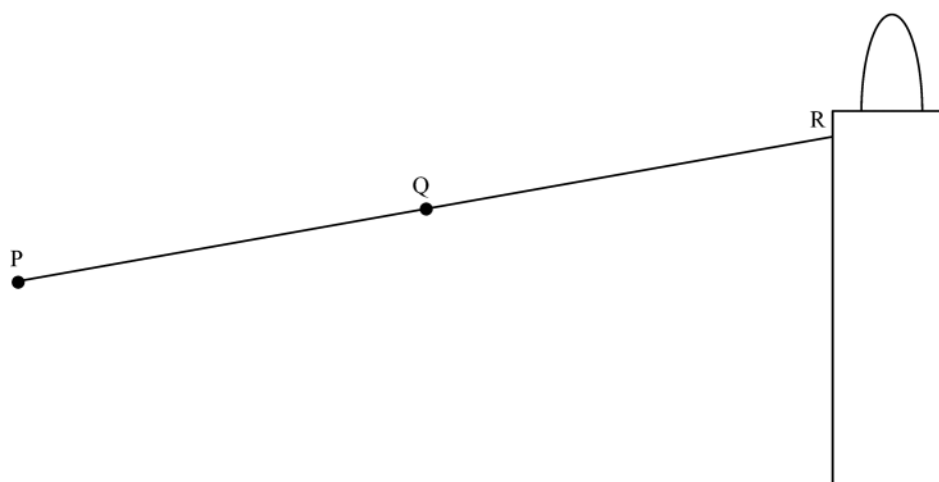

4. What do you notice about the diagram you have drawn as compared to the given diagram?
5. Take another piece of elastic and mark P and next Q, 3 cm from P and R, 6 cm from Q.

Use your elastograph to enlarge the shape below. Keep P fixed, place the pencil at R and stretch such that Q follows the shape.

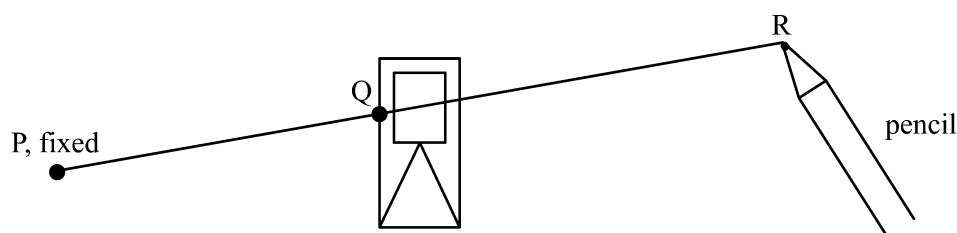

6. How many times larger is your diagram than the original?
7. If you place the first mark Q, 3 cm from P where are you to place R if you want to enlarge the original 4 times? 5 times?
8. Make your own design and enlarge it.

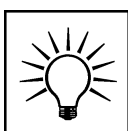

### Unit 3, Practice activity 6

1. Choose one of the stated aspects (i - viii) to be covered under enlargement and develop/extend the objective of the example question into a complete class activity. Ensure you cover all possible cases with (i) the centre of enlargement outside, on or inside the shape (ii) a variety of positions of the shape (iii) using grid/coordinates or plain paper (iv) using a variety of scale factors.  
Try it out in your class and write an evaluative report.
2. Try out in a class the practical activity with the elastograph and compare with the more abstract method used in 1. Write an evaluative report specifically focussing on the reaction of the pupil. Which of the two methods gave a higher pupil involvement and led to greater enjoyment? Why was that the case?

*Present your assignment to your supervisor or study group for discussion.*





## Summary

Unit 3 has continued the practical approach to help your students understand geometrical transformations. By taking them from relatively concrete concepts like “enlargement” to the much more abstract “congruent” and “similar,” using practical manipulations throughout, it should prepare them for more complex geometry in subsequent years.



## Unit 3: Answers to self mark exercises



### Self mark exercise 1

Several methods can be used to obtain the images.

- (i) use of tracing paper: draw the original and the mirror line on the tracing paper and next flip over the tracing paper and place it with the mirror lines coinciding. Position of image can now be marked with sharp pencil or point of compass.
- (ii) use of ruler/set square/compasses to draw from each point lines perpendicular to the mirror line and measure (using the compasses) distances such that the original point is the same distance from the mirror line as its image.

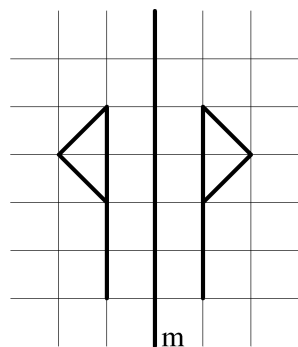

Figure 1

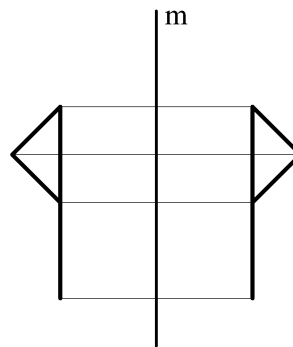

Figure 2

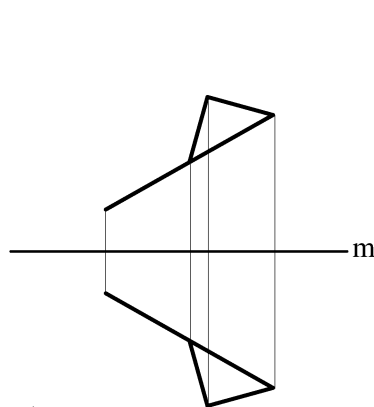

Figure 3

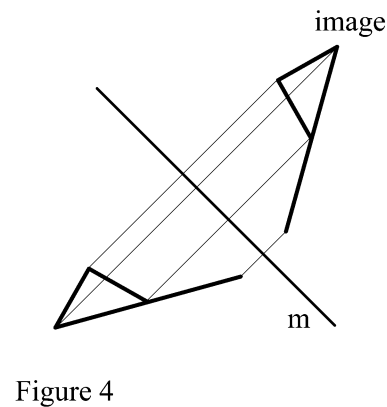

Figure 4

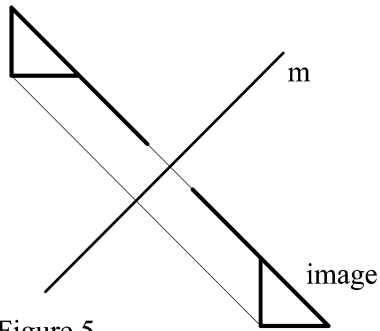

Figure 5

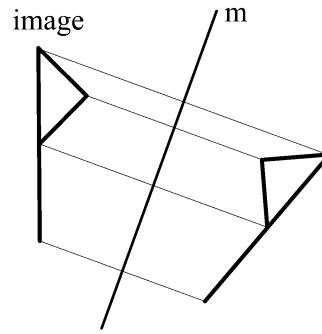

Figure 6



### Self mark exercise 2

#### Worksheet 1

3.  $90^\circ$   $PP'$  is perpendicular to the mirror line.
4.  $PS = PS'$ . Distance from P to the mirror line is equal to the distance from  $P'$  to the mirror line.
5. Points on the mirror line are their own image.

#### Worksheet 2

1. A line and its image meet on the mirror line.
2.  $AB$  and  $A'B'$  do not meet but are parallel.

If a line is parallel to the mirror line the image of the line is also parallel to the mirror line.

#### Worksheet 3

1.

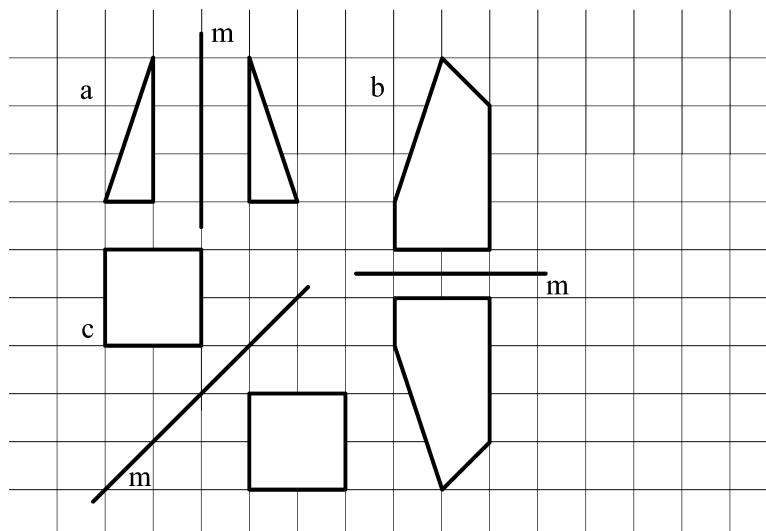

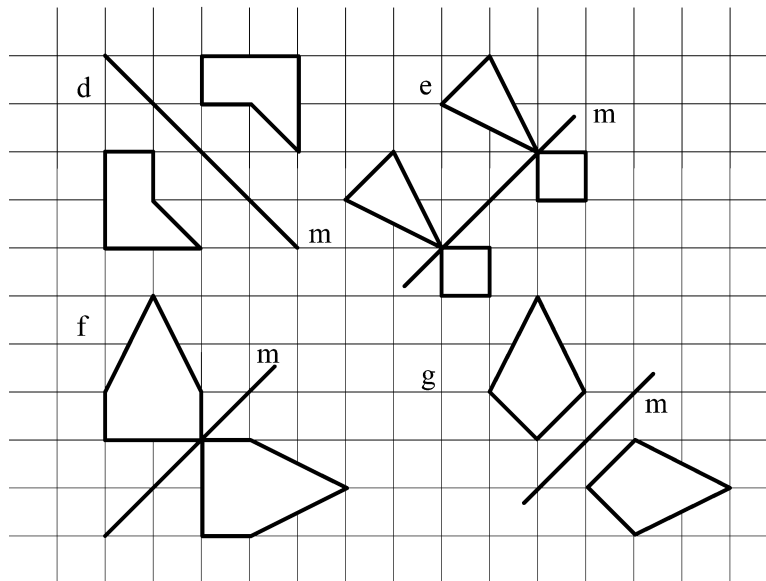

2. Corrections are needed for a, c, d, e, f and h.

#### Worksheet 4

- $(-3, 2)$     $(5, 2)$     $(2, 3)$     $(-7, -2)$     $(4, -5)$     $(1, 3)$     $(-4, 6)$   
 $(-5, -6)$     $(3, b)$     $(-a, 4)$     $(-a, b)$     $(-2a, 3b)$
- $(3, -2)$     $(-5, -2)$     $(-2, -3)$     $(7, 2)$     $(-4, 5)$     $(-1, -3)$     $(4, -6)$   
 $(5, 6)$     $(a, 3)$     $(4, -b)$     $(a, -b)$     $(2a, -3b)$
- $(2, 3)$     $(2, -5)$     $(3, -2)$     $(-2, 7)$     $(-5, -4)$     $(3, -1)$     $(6, 4)$   
 $(-6, 5)$     $(b, -3)$     $(4, a)$     $(b, a)$     $(3b, 2a)$
- $(-2, -3)$     $(-2, 5)$     $(-3, 2)$     $(2, -7)$     $(5, 4)$     $(-3, 1)$     $(-6, -4)$   
 $(6, -5)$     $(-b, 3)$     $(-4, -a)$     $(-b, -a)$     $(-3b, -2a)$
- $(-a, b)$     $(c, -d)$     $(f, e)$     $(-h, -g)$
- $(-3, -2)$     $(-5, 20)$     $(3.7, -2.3)$     $(2, -9)$     $(5.6, 3.5)$     $(32, 45)$   
 $(-8, 12)$     $(-7.3, 4.7)$   
 $x = y$     $x = 0$     $y = 0$     $x = -y$
5. If the two parallel (vertical) lines are distance  $d$  apart (if the lines have as equation  $x = a$  and  $x = b$  and the first reflection is in  $x = a$  followed by the reflection in  $x = b$  then  $d = b - a$ ) the double reflection is equivalent to a translation by the vector  $\begin{pmatrix} 2d \\ 0 \end{pmatrix}$
6. a)  $(6 - a, b)$    b)  $(a, 6 - b)$    c)  $(3 - b, 3 - a)$    d)  $(3 + b, a - 3)$
7.  $\left(\frac{y - n}{m}, mx + n\right)$  provided  $m \neq 0$

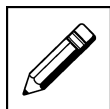
**Self mark exercise 3**

1. a)  $x = 1\frac{1}{2}$       b)  $x + y = 8$       c)  $y = 2\frac{1}{2}$   
 d)  $x = 2\frac{1}{2}$       e)  $y = x$       f)  $y = x$
2. a)  $x = 2$       b)  $y = 1$       c)  $x + y = 2$       d)  $y - x = 3$

**Self mark exercise 4**

3. a) Image of  $(a, b)$  is  $(b, -a)$   
 b) Image of  $(a, b)$  is  $(-a, -b)$   
 c) Image of  $(a, b)$  is  $(-b, a)$
4. a)  $-90^\circ$  or  $90^\circ$  depending which of the two shapes is taken as the original  
 b)  $180^\circ$   
 c)  $-90^\circ$  or  $90^\circ$  depending which of the two shapes is taken as the original  
 d)  $180^\circ$

**Self mark exercise 5**

2. f)

	a	b	c	d	e
A(-2, 1)	(-2, 4)	(-5, 1)	(0, 6)	(-4, -3)	(3, -5)
B(1, 1)	(1, 4)	(-2, 1)	(3, 6)	(-1, -3)	(6, -5)
C(-1, 5)	(-1, 8)	(-4, 5)	(1, 10)	(-3, 1)	(4, -1)
D(-3, 5)	(-3, 8)	(-6, 5)	(-1, 10)	(-5, 1)	(-2, -1)

g)  $P'(x + p, y + q)$ 

3. a)  $\begin{pmatrix} 3 \\ 4 \end{pmatrix}$       b)  $\begin{pmatrix} 0 \\ 3 \end{pmatrix}$       c)  $\begin{pmatrix} 2 \\ 1 \end{pmatrix}$       d)  $\begin{pmatrix} 1 \\ 0 \end{pmatrix}$
4. a)  $\begin{pmatrix} 8 \\ 0 \end{pmatrix}$       b)  $\begin{pmatrix} 3 \\ -2 \end{pmatrix}$       c)  $\begin{pmatrix} 1 \\ -6 \end{pmatrix}$       d)  $\begin{pmatrix} 8 \\ -7 \end{pmatrix}$
- e)  $\begin{pmatrix} -5 \\ -2 \end{pmatrix}$       f)  $\begin{pmatrix} -7 \\ -6 \end{pmatrix}$       g)  $\begin{pmatrix} -7 \\ 1 \end{pmatrix}$       h)  $\begin{pmatrix} 0 \\ 7 \end{pmatrix}$

5. a)  $\begin{pmatrix} 3 \\ 4 \end{pmatrix}$     b)  $\begin{pmatrix} 6 \\ 2 \end{pmatrix}$     c)  $\begin{pmatrix} 0 \\ -8 \end{pmatrix}$     d)  $\begin{pmatrix} 2 \\ -1 \end{pmatrix}$     e)  $\begin{pmatrix} -5 \\ 4 \end{pmatrix}$



### Self mark exercise 6

1. Congruent B and E, A and I, G and K, H and M  
Similar D and J, J and F, K and N, G and N and the above congruent shapes (congruent shapes are similar!)
2. C      C      B
3. b, e true, a, c, d false

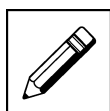

### Self mark exercise 7

1. No problems expected in the sample questions
2. a) true    b) false    c) false    d) true
3.  $S''$  is an enlargement of S by scale factor  $pq$ . This is rather straightforward if both enlargements have the same centre (say O).

$$(x, y) \Rightarrow (px, py) \Rightarrow (pqx, pqy)$$

If the first enlargement has centre  $A(a, b)$  and the second another centre  $B(c, d)$ , the resultant will be an enlargement with factor  $pq$  from a centre

$$C(c + apq + cq - aq, d + bpq + dq - bq).$$

## Unit 4: Transformations II

---



In this unit you will have a further look into transformation. The transformations considered are all linear transformations of the plane onto itself. These are the transformations that can be represented by linear expressions. The point  $P(x, y)$  maps onto  $P'(ax + by + c, dx + ey + f)$ , where  $a, b, c, d, e,$  and  $f$  are constants. When  $c = f = 0$  the origin  $O(0,0)$  maps onto itself—it is an invariant point. The transformation can be written in this case as  $\begin{pmatrix} x' \\ y' \end{pmatrix} = T \begin{pmatrix} x \\ y \end{pmatrix}$  where  $T$  is the matrix  $\begin{pmatrix} a & b \\ d & e \end{pmatrix}$ . If  $c$  and or  $f$  is not 0 the transformation does not leave  $O$  fixed. A translation is an example of such a transformation.

### Purpose of Unit 4

The purpose of this unit is to extend your knowledge on transformations by considering combination of transformations. If  $S$  and  $T$  represent transformations and  $A$  is a shape, you can look at the image of  $A$  under  $S$ , written as  $S(A)$ , and apply to the image the transformation  $T$ . The notation used is  $TS(A)$ . Take note of the order of writing!

This unit also looks at how linear transformations can be described using matrix notation. A point in two dimensional space can be represented by a column vector  $\begin{pmatrix} x \\ y \end{pmatrix}$ . Transformation onto a point  $\begin{pmatrix} x' \\ y' \end{pmatrix}$  can be described by a matrix multiplication  $\begin{pmatrix} x' \\ y' \end{pmatrix} = T \begin{pmatrix} x \\ y \end{pmatrix}$  where  $T$  is the transformation matrix and the origin  $O$  is a fixed point i.e. maps onto itself.

The teaching emphasis in this unit is on investigative work and looks at how to assess investigative work. You will be asked to investigate the above topics.



### Objectives

When you have completed this unit you should be able to:

- apply a combination of two transformation to a shape
- describe the single transformation equivalent to two successive transformations
- use the notation  $PQ(S)$  meaning the transformation  $Q$  followed by  $P$  applied to  $S$
- investigate commutativity of two successive transformations
- use matrices to describe transformation
- investigate the effect of basic transformation and combination of two of them
- use the given assessment scheme to assess pupils' investigative work



## **Time**

To study this unit will take you about 10 hours. Trying out and evaluating the activities with your pupils in the class will be spread over the weeks you have planned to cover the topic.